

SPECIFICATION

System Monitoring And Thermal Management

BMC-Teutates

Revision 1.21

Revision History

Rev.	Date	Changes and comments	Name
0.50		<ul style="list-style-type: none">• First Draft	HWD
1.00	2015-05-26	<ul style="list-style-type: none">• First release	HWD
1.10	2015-11-11	<ul style="list-style-type: none">• Adopted to Internal Spec 1.02	HWD
1.17	2015-12-18	<ul style="list-style-type: none">• Adopted to Internal Spec 1.17	HWD
1.19	2016-05-20	<ul style="list-style-type: none">• Adopted to Internal Spec 1.19• Fan and Sensor Control Registers added	HWD
1.20	2016-06-02	<ul style="list-style-type: none">• Fan and Sensor fail timeout Register added	HWD
1.21	2016-06-17	<ul style="list-style-type: none">• Watchdog description added	HWD
		<ul style="list-style-type: none">•	

Table of content

Revision History	2
Product features.....	4
System Monitoring	4
Thermal Management.....	4
Introduction.....	4
Overview	4
Northbridge PCH	4
Block diagram	5
Register description.....	5
General	5
SMBus Slave Address.....	5
Attribute	6
Register Overview	6
Global and device registers	8
Global registers.....	8
Global value Registers	10
Sensor configuration and status registers.....	13
Temperature sensor registers	13
Fan Registers	14
Fan configuration and status registers.....	14
Watchdog Timer	14
Hardware requirements.....	16
Fan	16
Tachometer Signal.....	16
Electrical Conditions 4- wire Fan	17
Temperature sensor location	17
Voltage measurement.....	17
12V Measurement.....	17
3.3V Measurement.....	17
3.3V Standby Measurement.....	17
Abbreviations	18

Product features

System Monitoring	Thermal Management
<p>Voltage Supervision</p> <ul style="list-style-type: none"> • Measurement of 12V • Measurement of 3.3V • Measurement of 3.3V AUX • Measurement of battery voltage • Measurement of battery voltage with Load (Optional) <p>Power on time counter</p> <ul style="list-style-type: none"> • Power on time is counted. <p>System interface</p> <ul style="list-style-type: none"> • Slave SMBus interface. • Proprietary SPI interface to Satellite devices. <p>System Restart</p> <ul style="list-style-type: none"> • System Heartbeat restarts. 	<p>Temperature regulation and supervision</p> <ul style="list-style-type: none"> • Up to two CPU digital interface (Intel®: PECI®; AMD®: AMDSI®), eight System and PCH temperature supervision (With Satellite). • Up to eight fans including power supply fan (with FTS power supply) supervision. (With Satellite). • Up to 16 characteristic curves possible. • Sensor failure mode. • System behaviour configurable as auto or performance PC. • Automatic minimal Fan rotation speed adjustment, selectable. <p>CPU and System thermal protection</p> <ul style="list-style-type: none"> • Temperature alerts. • CPU power reduction.

Introduction

Overview

The BMC Teutates is the Eleventh generation of Superior System monitoring and thermal management solution. It is builds on the basic functionality of the BMC Theseus and contains several new features and enhancements.

Northbridge PCH

Some temperature sensors are only accessible if Intel® PCH has a SMBus Slave Address of 0xE2h (8-bit). No other device is supported in BMC Teutates.

Block diagram

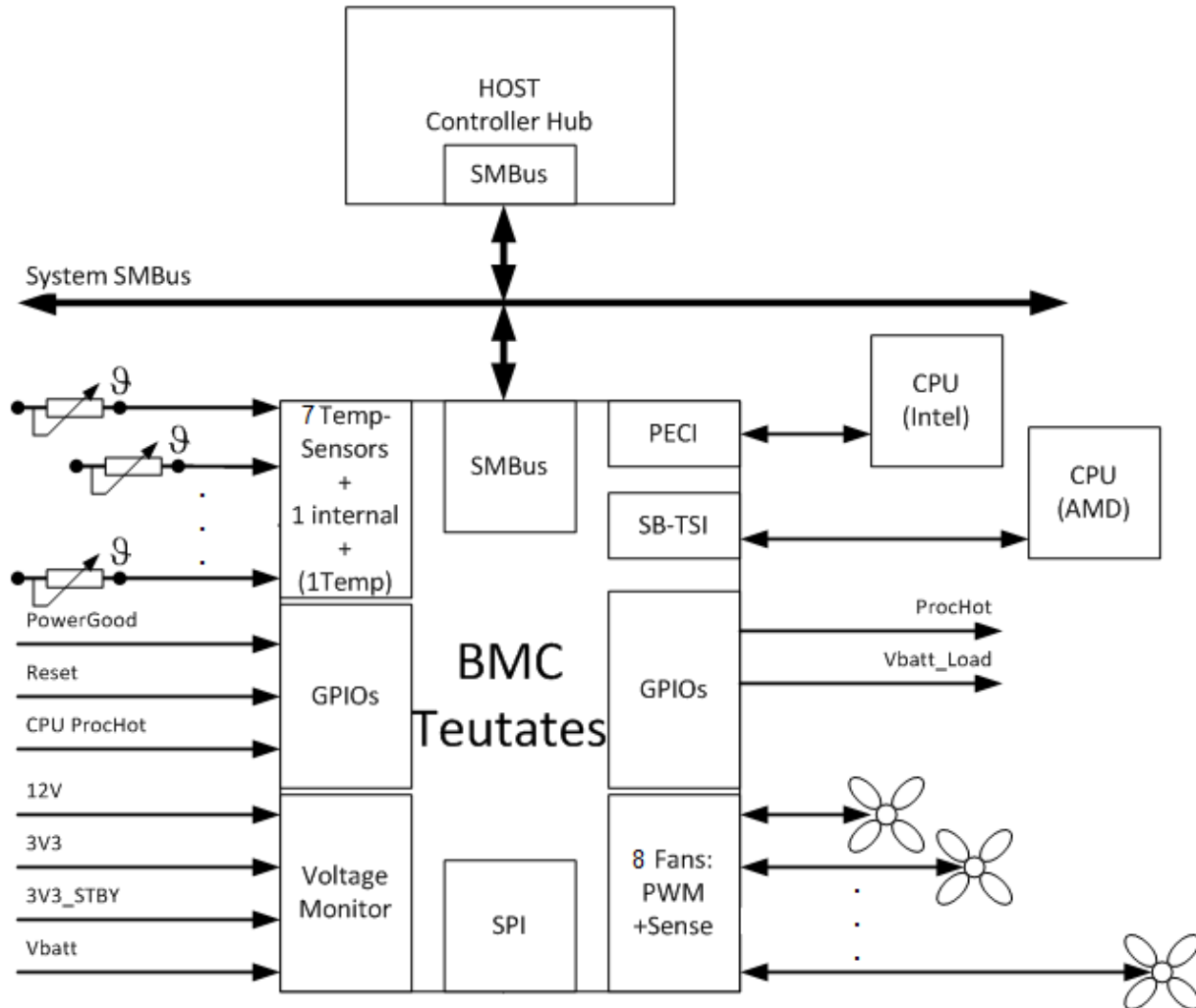

Register description

General

BMC Teutates has an I²C Bus interface. The register's structure provides the BMC Teutates configuration and all current measurement data. Every register has 8 bits and is fully readable. **DO NOT CHANGE RESERVED BITS** this may destroy the system board.

SMBus Slave Address

The SMBus (I²C) slave address of the BMC Teutates is

7Bit	7Bit + read => 8Bit	7Bit + write => 8Bit
73h	E7h	E6h

Attribute

- RO – Read only
- RC – Read Clear
- R/W – Read / Write
- R/WC – Read / Write Clear
- WO – Write only
- C – Clearable, set to 1 in order to clear status bit.
- * – Value is depending on SETUP options or BIOS configuration.
- R – Reserved Bit (do not change the value)

Register Overview

Page	Offset	Register Name / Function	Default	Access
00h	00h	Device ID register	-	RO
00h	01h	Device revision register	-	RO
00h	04h	Device status register	0x00	RO
00h	06h	global event status register	0x00	RO
00h	07h	Global Control Register	-	R/W
00h	0Bh	Watchdog Timer Pre Set Value Register	8	R/W
00h	10h	Global Sensor Event register Byte 0	0x00	RO
00h	11h	Global Sensor Event register Byte 1	0x00	RO
00h	14h	Global Fan Event register	0x00	RO
00h	15h	Global Fan Present register	-	RO
00h	18h	Vin2 Actual Value Register	-	RO
00h	19h	Vin3 Actual Value Register	-	RO
00h	1Ah	Vin1 Actual Value Register	-	RO
00h	1Bh	Vin4 Actual Value Register	-	RO
00h	20h	Actual Fan0 RPS Value Register	-	RO
00h	21h	Actual Fan1 RPS Value Register	-	RO
00h	22h	Actual Fan2 RPS Value Register	-	RO
00h	23h	Actual Fan3 RPS Value Register	-	RO
00h	24h	Actual Fan4 RPS Value Register	-	RO
00h	25h	Actual Fan5 RPS Value Register	-	RO
00h	26h	Actual Fan6 RPS Value Register	-	RO
00h	27h	Actual Fan7 RPS Value Register	-	RO
00h	30h	ActualFan0SpeedSensorSource Register	-	RO
00h	31h	ActualFan1SpeedSensorSource Register	-	RO
00h	32h	ActualFan2SpeedSensorSource Register	-	RO
00h	33h	ActualFan3SpeedSensorSource Register	-	RO
00h	34h	ActualFan4SpeedSensorSource Register	-	RO
00h	35h	ActualFan5SpeedSensorSource Register	-	RO
00h	36h	ActualFan6SpeedSensorSource Register	-	RO
00h	37h	ActualFan7SpeedSensorSource Register	-	RO
00h	40h	Actual SEN0 Temperature Value Register	-	RO
00h	41h	Actual SEN1 Temperature Value Register	-	RO

00h	42h	Actual SEN2 Temperature Value Register	-	RO
00h	43h	Actual SEN3 Temperature Value Register	-	RO
00h	44h	Actual SEN4 Temperature Value Register	-	RO
00h	45h	Actual SEN5 Temperature Value Register	-	RO
00h	46h	Actual SEN6 Temperature Value Register	-	RO
00h	47h	Actual SEN7 Temperature Value Register	-	RO
00h	48h	Actual SEN8 Temperature Value Register	-	RO
00h	49h	Actual SEN9 Temperature Value Register	-	RO
00h	4Ah	Actual SEN10 Temperature Value Register	-	RO
00h	4Bh	Actual SEN11 Temperature Value Register	-	RO
00h	4Ch	Actual SEN12 Temperature Value Register	-	RO
00h	4Dh	Actual SEN13 Temperature Value Register	-	RO
00h	4Eh	Actual SEN14 Temperature Value Register	-	RO
00h	4Fh	Actual SEN15 Temperature Value Register	-	RO
00h	7Ah	Power on Time Counter Value Byte0	0x00	R/W
00h	7Bh	Power on Time Counter Value Byte1	0x00	R/W
00h	7Ch	Power on Time Counter Value Byte2	0x00	R/W
00h	7Fh	Page Select Register	0x00	R/W
00h	80h	Global Sensor-Fail Behavior Register	0x35	R/W
00h	85h	Global Fan-Fail-Timeout	0x0A	R/W
06h	81h	SEN0 Control Register	0x08	RW
07h	81h	SEN1 Control Register	0x08	RW
08h	81h	SEN2 Control Register	0x08	RW
09h	81h	SEN3 Control Register	0x08	RW
0Ah	81h	SEN4 Control Register	0x08	RW
0Bh	81h	SEN5 Control Register	0x08	RW
0Ch	81h	SEN6 Control Register	0x08	RW
0Dh	81h	SEN7 Control Register	0x08	RW
0Eh	81h	SEN8 Control Register	0x08	RW
0Fh	81h	SEN9 Control Register	0x08	RW
10h	81h	SEN10 Control Register	0x08	RW
11h	81h	SEN11 Control Register	0x08	RW
12h	81h	SEN12 Control Register	0x08	RW
13h	81h	SEN13 Control Register	0x08	RW
14h	81h	SEN14 Control Register	0x08	RW
15h	81h	SEN15 Control Register	0x08	RW
48h	81h	FAN0 Control Register	0x20	R/W
49h	81h	FAN1 Control Register	0x20	R/W
4Ah	81h	FAN2 Control Register	0x20	R/W
4Bh	81h	FAN3 Control Register	0x20	R/W
4Ch	81h	FAN4 Control Register	0x20	R/W
4Dh	81h	FAN5 Control Register	0x20	R/W
4Eh	81h	FAN6 Control Register	0x20	R/W
4Fh	81h	FAN7 Control Register	0x20	R/W

50h	80h	Watchdog Timer Status Register	0x00	RO
50h	81h	Watchdog Timer Control Register	0x20	WO

Global and device registers

Global registers

Device ID register Page (00h) Offset (00h)

Bit	Function Description	Default	Access
7 – 4	The High-Nibble represents the device-class: 0xh - no class 1xh - Baseboard Management Controller 2xh - reserved for future use (Extension for 1xh) 3xh - Baseboard Management Satellite 4xh - reserved for future use (Extension for 3xh) 5xh - Exh – reserved for future use Fxh - Debug Trace Controller	1xh	RO
3 – 0	The Low-Nibble represents the device-ID: For device-class “Baseboard Management Controller”: x0h - not defined x1h - Teutates x2h - xFh - reserved for future use For other device-classes: x0h – reserved for future use	x1h	RO

Device revision register - Page (00h) Offset (01h)

Bit	Function Description	Default	Access
7 – 4	The low nibble represents the "post-dot" value of the device revision - e.g. 0x17 => revision 1.7	*xh	RO
3 – 0	The high nibble represents the "pre-dot" value of the device revision - e.g. 0x17 => revision 1.7	x*h	RO

Device status register - Page (00h) Offset (04h)

Bit	Function Description	Default	Access
7	Reserved	-	-
6	Reserved	-	-
5	Reserved	-	-
4	Reserved	-	-
3	Reserved	-	-
2	Reserved	-	-
1	Data-Valid Flag: 0 → Monitoring Data is NOT valid yet 1 → Monitoring Data is valid		RO
0	Device Ready: 0 → device is not initialized yet 1 → internal init (boot) of device is done		RO

Global event status register - Page (00h) Offset (06h)

The register reports the global event status bits.

Bit	Function Description	Default	Access
7	Global CPU throttling status 1b This Bit is set if one of the following states are reached: <ul style="list-style-type: none"> • CPU is activating TCC • TCC is activated because of a temperature sensor has reached its threshold value 0b TCC is neither activated by CPU nor BMC	-	RO
6	Reserved	-	-
5	Reserved	-	-
4	Global software event 1b A software-event is set.. This Bit reflects the software-event-bit in the Global Control Register - Page (00h) Offset (07h). To disable the event, you must clear the software-event-bit in the Global Control Register – Global Control Register - Page (00h) Offset (07h) 0b No software-event is set.	0b	RO
3	Reserved	-	-
2	Global Timer Event: 1b a timer event occurred 0b NO timer event occurred	0b	RO
1	Global over temperature or sensor working Alert 1b A sensor does have a problem. To disable the alert, the alert-clear-bit in the Sensor Control Register of the related sensor-page must be set. 0b No Temperature or Sensor alert occurred.	0b	RO
0	Global Fan fault event 1b A fan does have a problem. To disable the alert, the alert-clear-bit in the Fan Control Register of the related fan-page must be set. 0b No Fan fault occurred.	0b	RO

Global Control Register - Page (00h) Offset (07h)

Bit	Function Description	Default	Access
7	Reserved	0b	-
6	Vbat Measurement 1b Measurement of Vbat initiated or in progress. This bit is self-clearing. 0b No Measurement of Vbat is initiated or in progress.	0b	R/W self clearing
5	Vbat Load enable: 1b Load for Vbat measurement is enabled 0b Load for Vbat measurement is disabled NOTE: this bit will NOT trigger a battery measurement, just define, if the measurement is done with load. ATTENTION: if battery measurement with load is enabled, a frequent measurement will speed up the discharge of the battery!	0b	R/W
4	Alert LED Signalling 1b Alert signalling is split to two LEDs. 0b All alerts are shown via one LED.	0b	R/W
3	Reserved	0b	-
2	Reserved	0b	-

Bit	Function Description	Default	Access
1	<p>Software Event control</p> <p>1b the Software Event is enabled and will be set in the Global event status register - Page (00h) Offset (06h)</p> <p>0b the Software Event is disabled and will be cleared in the Global event status register - Page (00h) Offset (06h)</p> <p>Note: If the Alert-LED is enabled (bit0 of this register) a Software Event will be signalled via Alert LED</p>	0b	R/W
0	<p>Alert LED control</p> <p>1b Alert LED is enabled.</p> <p>0b Alert LED is disabled.</p>	0b	R/W

Watchdog Timer Pre Set Value Register - Page (00h) Offset (0Bh)

The register provides the pre-set value of the watchdog. Writing this register will start or retrigger the watchdog countdown. Writing a value of 0 will stop the watchdog.

Bit	Function Description	Default	Access
7 - 0	<p>Pre-set watchdog status</p> <p>The value specifies the watchdog timer timeout value in minutes. When a value of 0 is read the timer is stopped. On values other than 0 the timer is running..</p>	8	R/W

Global value Registers

Global Sensor Event register - Page (00h) Offset (10h)

Bit	Function Description	Default	Access
15 - 0	<p>Shows if a sensor has any event active in its status-register.</p> <p>BitX = 0 => SensorX does not have any event active in its status register</p> <p>BitX = 1 => SensorX does have an event active in its status register</p>	0000h	RO

Global Fan Event register - Page (00h) Offset (14h)

Bit	Function Description	Default	Access
7 - 0	<p>Shows if a fan has any event active in its status-register.</p> <p>BitX = 0 => FanX does not have any event active in its status register</p> <p>BitX = 1 => FanX does have an event active in its status register; detailed event information shows the FanX status register</p>	00h	RO

Global Fan Present register - Page (00h) Offset (15h)

Bit	Function Description	Default	Access
-----	----------------------	---------	--------

Bit	Function Description	Default	Access
7 - 0	Shows each detected fan at its Bit-Position: Bit-N = 0 => The Fan-N was NOT detected as present Bit-N = 1 => The Fan-N was detected as present The present-detection is done by checking the Fan-Speed. If the fan-speed is 0 or below fan-fault-speed all the time, the fan will be handled as not present. If the fan-speed is greater than fan-fault-speed, the fan is handled as present.	00h	RO

Vin2 Actual Value Register - Page (00h) Offset (18h)

Bit	Function Description	Default	Access
7 - 0	Actual Vin2 value All inputs are limited to a maximum voltage of 3.3V due to an internal setting of Vref = 3.3V (3.3V / 4096 steps => LSB = 805µV). This register only shows the leading 8 bit with (3.3V / 256 steps => LSB = 12.9mV). All inputs to the ADC must limit the maximum voltage by using a voltage divider. External Divider used on the motherboard see Systemboard Specification. To calculate the measured Voltage use following formula. <i>Actual_Value</i> $= \left(\frac{\text{BoardMultiplier} * \text{RegValue} * \text{Vref}}{256} \right) / 100$	-	RO

Vin3 Actual Value Register - Page (00h) Offset (19h)

Bit	Function Description	Default	Access
7 - 0	Actual Vin3 value All inputs are limited to a maximum voltage of 3.3V due to an internal setting of Vref = 3.3V (3.3V / 4096 steps => LSB = 805µV). This register only shows the leading 8 bit with (3.3V / 256 steps => LSB = 12.9mV). All inputs to the ADC must limit the maximum voltage by using a voltage divider. External Divider used on the motherboard see Systemboard Specification. To calculate the measured Voltage use following formula. <i>Actual_Value</i> $= \left(\frac{\text{BoardMultiplier} * \text{RegValue} * \text{Vref}}{256} \right) / 100$	-	RO

Vin1 Actual Value Register - Page (00h) Offset (1Ah)

Bit	Function Description	Default	Access
-----	----------------------	---------	--------

Bit	Function Description	Default	Access
7 - 0	<p>Actual Vin1 value All inputs are limited to a maximum voltage of 3.3V due to an internal setting of Vref = 3.3V (3.3V / 4096 steps => LSB = 805µV). This register only shows the leading 8 bit with (3.3V / 256 steps => LSB = 12.9mV). All inputs to the ADC must limit the maximum voltage by using a voltage divider. External Divider used on the motherboard see Systemboard Specification. To calculate the measured Voltage use following formula. <i>Actual_Value</i> = $(\frac{BoardMultiplier * RegValue * Vref}{256})/100$</p>	-	RO

Vin4 Actual Value Register - Page (00h) Offset (1Bh)

The battery-voltage is measured on each Sx => S0. If the value should be updated additionally, this can be triggered by setting bit6 in the Global Control Register - Page (00h) Offset (07h)

Bit	Function Description	Default	Access
7 - 0	<p>Actual Vin4 value All inputs are limited to a maximum voltage of 3.3V due to an internal setting of Vref = 3.3V (3.3V / 4096 steps => LSB = 805µV). This register only shows the leading 8 bit with (3.3V / 256 steps => LSB = 12.9mV). All inputs to the ADC must limit the maximum voltage by using a voltage divider. External Divider used on the motherboard see Systemboard Specification. To calculate the measured Voltage use following formula. <i>Actual_Value</i> = $(\frac{BoardMultiplier * RegValue * Vref}{256})/100$</p>	-	RO

FanX Actual RPS speed Register - Page (00h) Offset (20h) to (27h)

Bit	Function Description	Default	Access
7 - 0	<p>Actual Fan-Speed in Rounds Per Second 00h Fan does not rotate FFh 255 rps (=15300 RPM)</p>	-	RO

FanX Actual Sensor Source Register - Page (00h) Offset (30h) to (37h)

Bit	Function Description	Default	Access
7 - 0	<p>Which sensor does actually define the fan-speed: This register represents the sensor-number of the sensor that does actually define the fan-speed. When there is no sensor defining the fan speed, because the fan may be forced to full speed or the sensors' regulation start temperature isn't reached, the value is set to 0xFF. This particular value should be interpreted as 'none'.</p>	-	RO

SensorX Actual Temperature Value Register - Page (00h) Offset (40h) to (4Fh)

Bit	Function Description	Default	Access
7 - 0	Actual SensorX temperature value 00h Temperature = Sensor Error 01h Temperature = - 63 ¹ 40h Temperature = 0 ¹ FFh Temperature = + 191 ¹	-	RO

Power on time counter Value Registers - Page (00h) Offset (7Ah) to (7Ch)

Bit	Function Description	Default	Access
23 - 0	Power on time counter value These Registers contain the time in minutes which the System is on. 007Ch contains the most significant byte MSB. 007Ah contains the least significant byte LSB.	00 00 00h	R/W

Page Select Register - Page (00h) Offset (7Fh)

Bit	Function Description	Default	Access
7 - 0	This register allows to select different register pages	00h	R/W

Register Pages:

Page-#	Name	Description
0 [00h]	Global-Page	Device-ID global Events, Values and Configuration
6 - 21 [06h - 15h]	Sensor0-15 - Pages	Sensor related registers
72 - 79 [48h - 4Fh]	Fan0-7 - Pages	Fan related pages (e.g. physical layer)

Global Sensor-Fail Behaviour Register - Page (00h) Offset (80h)

Bit	Function Description	Default	Access
7 - 4	Reserved	3h	R/W
3 - 0	Global Sensor fail timeout: The time in seconds when successive temperature readings exceeding the over temperature threshold until a sensor alert is set.	5h	R/W

Global Fan- Timeouts - Page (00h) Offset (85h)

Bit	Function Description	Default	Access
7 - 4	Reserved	0h	R/W
3 - 0	Global fan fail timeout: The time in seconds until a not rotating fan will be set to fan-fail.	Ah	R/W

Sensor configuration and status registers

Temperature sensor registers

¹ For CPU1SEN1, CPU1SEN2 and CPU2SEN1 this value is in DTS all others are in °C.

SensorX Control Register - Page (06h) to (15h) Offset (81h)

Bit	Function Description	Default	Access
7	Reserved	0b	R/W
5-4	Reserved	0b	R/W
3	Reserved	1b	R/W
2	Reserved	0b	R/W
1	Reserved	0b	R/W
0	<p>Clear Sensor Alerts Writing 1 to this bit will clear all pending sensor alert/event Note: The firmware will reset alert flag instantly and reassign the flag on the next poll cycle. Therefore it is recommended to wait at least 1 second before checking alert the next time. Please be aware that the time to set Sensor Alert is defined in Global Sensor-Fail Behaviour Register - Page (00h) Offset (80h).</p>	-	WO

Fan Registers

Fan configuration and status registers

FanX Control Register - Page (48h) to (4Fh) Offset (81h)

Bit	Function Description	Default	Access
7	Reserved	0b	R/W
6 - 5	Reserved	01b	R/W
4 - 3	Reserved	-	-
2	Reserved	0b	R/W
1	Reserved	0b	R/W
0	<p>Clear Fan Alert Writing 1 to this bit will clear pending fan alert/event Note: The firmware will reset all alert flag instantly and reassign the flag on the next poll cycle. Therefore it is recommended to wait at least 1 second before checking alert the next time. Please be aware that the time to set Fan Alert is defined in Global Fan- Timeouts - Page (00h) Offset (85h)</p>	0b	WO

Watchdog Timer

The watchdog-timer is a software watchdog and NOT the internal hardware watchdog. If the watchdog timer is up and running und not retrigged in time the system may be reset (depends on configuration).

Watchdog Timer Status Register - Page (50h) Offset (80h)

Bit	Function Description	Default	Access
-----	----------------------	---------	--------

Bit	Function Description	Default	Access
7 – 4	Watchdog Timer Type: The type determines which kind of watchdog was running when the last timer event occurred. 0h Unknown 1h HW Watchdog 2h POST Watchdog 3h Boot Watchdog 4h SW Watchdog	0h	RO
3 – 2	Reserved	00b	RO
1	Watchdog Timer event: 1b a watch-dog timer event occurred 0b no watch-dog timer event occurred	0b	RO
0	Reserved	0b	RO

Watchdog Timer Control Register - Page (50h) Offset (81h)

The register provides the function control on the watchdog.

Bit	Function Description	Default	Access
7 - 4	Reserved	2h	R/W
3	Reserved	0b	R/W
2	Reserved	0b	R/W
1	Set watchdog time base: 1b time base is 1 seconds 0b time base is 60 seconds	0b	R/W
0	Clear watchdog-timer alerts 1b clear pending watchdog-timer alerts 0b no effect	-	WO

Hardware requirements

Fan

4- Wire fans have to be used.

Fans have to start with a PWM Value of 30%.

Tachometer Signal

Power Supply

To get a correct result of Power Supply fan speed the used fan has to meet the following condition.

Tachometer output of fan should be an open collector output.

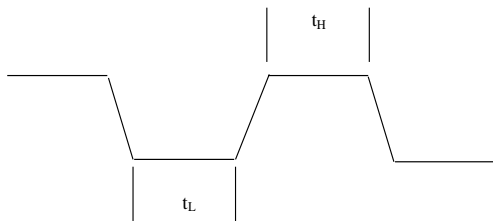

	Minimum	Maximum	
t_H	600	-	μs
t_L	600	-	μs

Only one Fan can be connected to one Tachometer input.

4-Wire Fans

To get a correct result of fan speed the used fan has to meet the following condition. Tachometer output of fan should be an open collector output.

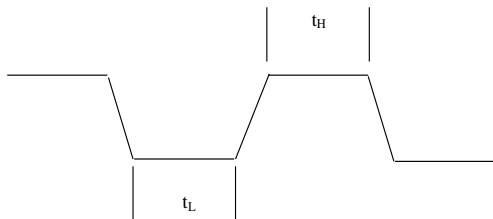

	Minimum	Maximum	
t_H	3	-	μs
t_L	3	-	μs

Electrical Conditions 4- wire Fan

4-wire Fan has to fulfill these electrical conditions. Fans do not have to have a Pull up implemented into PWM line. Some conditions are depending on the implementation on the motherboard. Please refer to system board manual.

	Minimum	Typical	Maximum	
PWM frequency	22.5	25	27.5	kHz
PWM start up value	-	-	30	%
Operating Voltage	TBD	TBD	TBD	V
Input Current	TBD	TBD	TBD	A
Blocked Current	TBD	TBD	TBD	A
Control signal input high level	2.8	3.3	12	V
Control signal input low level	-0.2	0	0.8	V
Fan start up time after setting PWM value from zero to start up value.	0	1	3	s

Temperature sensor location

For the location of temperature sensors on motherboard please refer to System board manual.

Voltage measurement

Voltage is measured with a 12 bit AD converter. All inputs are limited to a maximum voltage of 3.3V due to an internal setting of 805 μ V LSB (4096 steps x 805 μ V = 3.297V). All inputs to the ADC must limit the maximum voltage by using a voltage divider. All divider Resistors have to have a 1% tolerance.

12V Measurement

For 12V Measurement maximum measurable Voltage is 12.87V.

3.3V Measurement

For 3.3V maximum measurable Voltage is 3.63V.

3.3V Standby Measurement

For 3.3V standby maximum measurable Voltage is 3.63V.

Abbreviations

abbreviation	Explanation
AMD TSI®	AMD Thermal Serial Interface
BMC	Baseboard Management Controller
CRC16	16Bit Cyclic Redundancy Check ⇒ http://de.wikipedia.org/wiki/Zyklische_Redundanzpr%C3%BCfung ⇒ https://en.wikipedia.org/wiki/Crc16
HPC	High Performance Computing
PECI®	Platform Environment Control Interface
PWM	Pulse Width Modulation
SMB	System Management Bus
SMCO	System Management Control Overwrite
SMCS	System Management Control Settings
SMI	System Management Interrupt